



Rechargeable Digital Torque Tools

PRECISION

INNOVATION

PERFECTION



TABLE OF CONTENTS

Product Features	2
Rechargeable Digital Torque Wrench	4
Rechargeable Digital Interchangeable Torque Wrench	6
Rechargeable Digital Flexible Torque Wrench	7
Rechargeable Digital Torque Adapter	8
Rechargeable Digital Angle Torque Wrench	10
Rechargeable Digital Interchangeable & Angle Torque Wrench	12
Rechargeable Digital Flexible & Angle Torque Wrench	13
Rechargeable Digital Angle Torque Adapter	14
Packing Specification	15
Technical Data	17

Product Features



LCD Display



Common Specification

Operation Memory Setting	30 Sets
Warning light	2 LED (1 GREEN + 1 RED)
Vibration warning	Yes (activate when set value reaches 90%)
Mode	Peak hold(K) / Track(F) / Angle(A)
Unit	Nm, kg.cm, lb-in, lb-ft
Battery life (fully charged used time)	10-14 hrs
Battery life (recharge time)	90-120 mins
Storage conditions (Temperature)	Recharge : 10°C ~ 45°C Discharge : -10°C ~ 60°C Storage : -20°C ~ 25°C (< 1 year) -20°C ~ 40°C (< 3 months) -20°C ~ 50°C (< 1 month)
Storage conditions (Humidity)	Work : 20% ~ 85%RH (not condensed) Storage : 40% ~ 85%RH (not condensed)
Drop test	1m
Vibration test	10G
Life test	10000 cycle
Environmental test	Pass
EMC test	Pass



R ECHARGEABLE



PRECISION



DIGITAL

SH-CHTQ Series

Rechargeable Digital Torque Wrench



SPECIFICATION

Model No.	SH-CHTQ30-1	SH-CHTQ30-2	SH-CHTQ60-2	SH-CHTQ135-2	SH-CHTQ135-3	SH-CHTQ200-3
Accuracy	CW:±1.5% CCW:±2.5%					
Gear Teeth	72					
Driver	1/4"	3/8"			1/2"	
Max. Torque	30Nm		60Nm	135Nm		200Nm
Setting Range	1.5~30 Nm 1.11~22.13 lb.ft 13.3~265.5 lb.in 15.3~305.9 kg.cm		3~60 Nm 2.21~44.25 lb.ft 26.6~531 lb.in 30.6~611.8 kg.cm	6.8~135 Nm 5.0~99.6 lb.ft 60~1195 lb.in 69~1377 kg.cm		10~200 Nm 7.4~147.5 lb.ft 89~1770 lb.in 102~2039 kg.cm
Min. Scale Units	0.01 Nm / 0.01 lb.ft / 0.1 lb.in / 0.1 kg.cm			0.1 Nm / 0.1 lb.ft / 1 lb.in / 1 kg.cm		
Max. Torque Load/ DIN Standards	88.0/62.0 Nm	294.0/202.0 Nm			735.0/512.0 Nm	

SPECIFICATION

Model No.	SH-CHTQ340-3	SH-CHTQ600-4	SH-CHTQ800-4	SH-CHTQ800-5	SH-CHTQ1000-4	SH-CHTQ1000-5
Accuracy	CW:±1.5% CCW:±2.5%					
Gear Teeth	72	24				
Driver	1/2"	3/4"		1"	3/4"	1"
Max. Torque	340Nm	600Nm	800Nm		1000Nm	
Setting Range	17~340 Nm 12.5~250.8 lb.ft 150~3009 lb.in 173~3467 kg.cm	60~600 Nm 44.3~442.5 lb.ft 531~5310 lb.in 612~6118 kg.cm	80~800 Nm 59~590 lb.ft 708~7081 lb.in 816~8158 kg.cm		100~1000 Nm 73.8~737.6 lb.ft 885~8851 lb.in 10.2~102.0 kg.m	
Min. Scale Units	0.1 Nm / 0.1 lb.ft / 1 lb.in / 1 kg.cm				1 Nm / 0.1 lb.ft / 1 lb.in / 0.1 kg.m	
Max. Torque Load/ DIN Standards	735.0/512.0 Nm	1836/1412 Nm		3270/2515 Nm	1836/1412 Nm	3270/2515 Nm



SH-CHTI Series

Rechargeable Digital Interchangeable Torque Wrench



SPECIFICATION

Model No.	SH-CHTI30-1	SH-CHTI30-2	SH-CHTI60-2	SH-CHTI135-2	SH-CHTI135-3	SH-CHTI200-3	SH-CHTI340-3
Accuracy	CW:±2% CCW:±3%						
Square Insert	9x12 mm				14x18 mm		
Driver	1/4"	3/8"			1/2"		
Max. Torque	30Nm		60Nm	135Nm		200Nm	340Nm
Setting Range	3~30 Nm 2.21~22.13 lb.ft 26.6~265.5 lb.in 30.6~305.9 kg.cm		6~60 Nm 4.43~44.25 lb.ft 53.1~531 lb.in 61.2~611.8 kg.cm	13.5~135 Nm 10~99.6 lb.ft 119~1195 lb.in 138~1377 kg.cm		20~200 Nm 14.8~147.5 lb.ft 177~1770 lb.in 204~2039 kg.cm	34~340 Nm 25.1~250.8 lb.ft 301~3009 lb.in 347~3467 kg.cm
Min. Scale Units	0.01 Nm / 0.01 lb.ft / 0.1 lb.in / 0.1 kg.cm			0.1 Nm / 0.1 lb.ft / 1 lb.in / 1 kg.cm			
Max. Torque Load/ DIN Standards	88.0/62.0 Nm	294.0/202.0 Nm			735.0/512.0 Nm		

SH-CHTF Series

Rechargeable Digital Flexible Torque Wrench



SPECIFICATION

Model No.	SH-CHTF30-1	SH-CHTF135-2	SH-CHTF200-3	SH-CHTF340-3
Accuracy	CW:±2% CCW:±3%			
Gear Teeth	72			
Driver	1/4"	3/8"	1/2"	
Max. Torque	30Nm	135Nm	200Nm	340Nm
Setting Range	3~30 Nm 2.21~22.13 lb.ft 26.6~265.5 lb.in 30.6~305.9 kg.cm	13.5~135 Nm 10~99.6 lb.ft 119~1195 lb.in 138~1377 kg.cm	20~200 Nm 14.8~147.5 lb.ft 177~1770 lb.in 204~2039 kg.cm	34~340 Nm 25.1~250.8 lb.ft 301~3009 lb.in 347~3467 kg.cm
Min. Scale Units	0.01 Nm 0.01 lb.ft 0.1 lb.in 0.1 kg.cm	0.1 Nm / 0.1 lb.ft / 1 lb.in / 1 kg.cm		
Max. Torque Load/ DIN Standards	88.0/62.0 Nm	294.0/202.0 Nm	735.0/512.0 Nm	

SH-CHTS Series

Rechargeable Digital Torque Adapter



SPECIFICATION

Model No.	SH-CHTS60-1	SH-CHTS135-1	SH-CHTS200-2	SH-CHTS340-2
Accuracy	CW:±1.5% CCW:±2.5%			
Inches	3/8"		1/2"	
Max. Torque	60Nm	135Nm	200Nm	340Nm
Setting Range	3~60 Nm 2.21~44.25 lb.ft 26.6~531 lb.in 30.6~611.8 kg.cm	6.8~135 Nm 5.0~99.6 lb.ft 60~1195 lb.in 69~1377 kg.cm	10~200 Nm 7.4~147.5 lb.ft 89~1770 lb.in 102~2039 kg.cm	17~340 Nm 12.5~250.8 lb.ft 150~3009 lb.in 173~3467 kg.cm
Min. Scale Units	0.01 Nm 0.01 lb.ft 0.1 lb.in 0.1 kg.cm	0.1 Nm / 0.1 lb.ft / 1 lb.in / 1 kg.cm		
Max. Torque Load/ DIN Standards	306.0/202.0 Nm		796.0/512.0 Nm	



R ECHARGEABLE



INNOVATION

**NEW
UPGRADE**



SH-CHTA Series

Rechargeable Digital Angle Torque Wrench



SPECIFICATION

Model No.	SH-CHTA30-1	SH-CHTA30-2	SH-CHTA60-2	SH-CHTA135-2	SH-CHTA135-3	SH-CHTA200-3	
Accuracy	CW:±1.5% CCW:±2.5% ∠ :±2°						
Gear Teeth	72						
Driver	1/4"	3/8"			1/2"		
Max. Torque	30Nm		60Nm	135Nm		200Nm	
Max. Angle	360°						
Setting Range	1.5~30 Nm 1.11~22.13 lb.ft 13.3~265.5 lb.in 15.3~305.9 kg.cm 0.1°~360°		3~60 Nm 2.21~44.25 lb.ft 26.6~531 lb.in 30.6~611.8 kg.cm 0.1°~360°		6.8~135 Nm 5.0~99.6 lb.ft 60~1195 lb.in 69~1377 kg.cm 0.1°~360°		10~200 Nm 7.4~147.5 lb.ft 89~1770 lb.in 102~2039 kg.cm 0.1°~360°
Min. Scale Units	0.01 Nm / 0.01 lb.ft / 0.1 lb.in / 0.1 kg.cm / 0.1°			0.1 Nm / 0.1 lb.ft / 1 lb.in / 1 kg.cm / 0.1°			
Max. Torque Load/ DIN Standards	88.0/62.0 Nm		294.0/202.0 Nm		735.0/512.0 Nm		



SPECIFICATION

Model No.	SH-CHTA340-3	SH-CHTA600-4	SH-CHTA800-4	SH-CHTA800-5	SH-CHTA1000-4	SH-CHTA1000-5
Accuracy	CW:±1.5% CCW:±2.5% ∠ :±2°					
Gear Teeth	72	24				
Driver	1/2"	3/4"		1"	3/4"	1"
Max. Torque	340Nm	600Nm	800Nm		1000Nm	
Max. Angle	360°					
Setting Range	17~340 Nm 12.5~250.8 lb.ft 150~3009 lb.in 173~3467 kg.cm 0.1°~360°	60~600 Nm 44.3~442.5 lb.ft 531~5310 lb.in 612~6118 kg.cm 0.1°~360°	80~800 Nm 59~590 lb.ft 708~7081 lb.in 816~8158 kg.cm 0.1°~360°		100~1000 Nm 73.8~737.6 lb.ft 885~8851 lb.in 10.2~102.0 kg.m 0.1°~360°	
Min. Scale Units	0.1 Nm / 0.1 lb.ft / 1 lb.in / 1 kg.cm / 0.1°				1 Nm 0.1 lb.ft 1 lb.in 0.1 kg.m 0.1°	
Max. Torque Load/ DIN Standards	735.0/512.0 Nm	1836/1412 Nm		3270/2515 Nm	1836/1412 Nm	3270/2515 Nm

SH-CHIA Series

Rechargeable Digital Interchangeable & Angle Torque Wrench



SPECIFICATION

Model No.	SH-CHIA30-1	SH-CHIA30-2	SH-CHIA60-2	SH-CHIA135-2	SH-CHIA135-3	SH-CHIA200-3	SH-CHIA340-3	
Accuracy	CW:±2% CCW:±3% ∠ :±2°							
Square Insert	9x12 mm				14x18 mm			
Driver	1/4"	3/8"			1/2"			
Max. Torque	30Nm		60Nm	135Nm		200Nm	340Nm	
Max. Angle	360°							
Setting Range	3~30 Nm 2.21~22.13 lb.ft 26.6~265.5 lb.in 30.6~305.9 kg.cm 0.1°~360°		6~60 Nm 4.43~44.25 lb.ft 53.1~531 lb.in 61.2~611.8 kg.cm 0.1°~360°		13.5~135 Nm 10~99.6 lb.ft 119~1195 lb.in 138~1377 kg.cm 0.1°~360°		20~200 Nm 14.8~147.5 lb.ft 177~1770 lb.in 204~2039 kg.cm 0.1°~360°	
Min. Scale Units	0.01 Nm / 0.01 lb.ft / 0.1 lb.in / 0.1 kg.cm / 0.1°			0.1 Nm / 0.1 lb.ft / 1 lb.in / 1 kg.cm / 0.1°				
Max. Torque Load/ DIN Standards	88.0/62.0 Nm		294.0/202.0 Nm			735.0/512.0 Nm		

SH-CHFA Series

Rechargeable Digital Flexible & Angle Torque Wrench



SPECIFICATION

Model No.	SH-CHFA30-1	SH-CHFA135-2	SH-CHFA200-3	SH-CHFA340-3
Accuracy	CW:±2% CCW:±3% ∠ :±2°			
Gear Teeth	72			
Driver	1/4"	3/8"	1/2"	
Max. Torque	30Nm	135Nm	200Nm	340Nm
Max. Angle	360°			
Setting Range	3~30 Nm 2.21~22.13 lb.ft 26.6~265.5 lb.in 30.6~305.9 kg.cm 0.1°~360°	13.5~135 Nm 10~99.6 lb.ft 119~1195 lb.in 138~1377 kg.cm 0.1°~360°	20~200 Nm 14.8~147.5 lb.ft 177~1770 lb.in 204~2039 kg.cm 0.1°~360°	34~340 Nm 25.1~250.8 lb.ft 301~3009 lb.in 347~3467 kg.cm 0.1°~360°
Min. Scale Units	0.01 Nm 0.01 lb.ft 0.1 lb.in 0.1 kg.cm 0.1°	0.1 Nm / 0.1 lb.ft / 1 lb.in / 1 kg.cm / 0.1°		
Max. Torque Load/ DIN Standards	88.0/62.0 Nm	294.0/202.0 Nm	735.0/512.0 Nm	

SH-CHTSA Series

Rechargeable Digital Angle Torque Adapter



SPECIFICATION

Model No.	SH-CHTSA60-1	SH-CHTSA135-1	SH-CHTSA200-2	SH-CHTSA340-2
Accuracy	CW:±1.5% CCW:±2.5% ∠:±2°			
Inches	3/8"		1/2"	
Max. Torque	60Nm	135Nm	200Nm	340Nm
Max. Angle	360°			
Setting Range	3~60 Nm 2.21~44.25 lb.ft 26.6~531 lb.in 30.6~611.8 kg.cm 0.1°~360°	6.8~135 Nm 5.0~99.6 lb.ft 60~1195 lb.in 69~1377 kg.cm 0.1°~360°	10~200 Nm 7.4~147.5 lb.ft 89~1770 lb.in 102~2039 kg.cm 0.1°~360°	17~340 Nm 12.5~250.8 lb.ft 150~3009 lb.in 173~3467 kg.cm 0.1°~360°
Min. Scale Units	0.01 Nm 0.01 lb.ft 0.1 lb.in 0.1 kg.cm 0.1°	0.1 Nm / 0.1 lb.ft / 1 lb.in / 1 kg.cm / 0.1°		
Max. Torque Load/ DIN Standards	306.0/202.0 Nm		796.0/512.0 Nm	



Rechargeable Digital Torque Wrench Rechargeable Digital Angle Torque Wrench

Model No.	Wrench Length	Wrench Weight	Tool Box Size L×W×H(mm)	Quantity (pcs)	Carton N.W.	Carton G.W.	Carton L×W×H(cm)	Cu.ft
SH-CHTQ30-1 SH-CHTA30-1	392mm	760g±50g	460×103×51	8	15.12kg	16.12kg	48.8×24.2×25.5	1.06
SH-CHTQ30-2 SH-CHTA30-2	392mm	785g±50g	460×103×51	8	15.30kg	16.30kg	48.8×24.2×25.5	1.06
SH-CHTQ60-2 SH-CHTA60-2	392mm	785g±50g	460×103×51	8	15.30kg	16.30kg	48.8×24.2×25.5	1.06
SH-CHTQ135-2 SH-CHTA135-2	418mm	888g±50g	578×103×51	6	13.44kg	14.44kg	60.6×24.2×19.7	1.02
SH-CHTQ135-3 SH-CHTA135-3	436mm	1104g±50g	578×103×51	6	14.72kg	15.72kg	60.6×24.2×19.7	1.02
SH-CHTQ200-3 SH-CHTA200-3	546mm	1262g±50g	697×103×51	4	12.00kg	13.00kg	72.7×24.2×13.6	0.84
SH-CHTQ340-3 SH-CHTA340-3	648mm	1460g±50g	697×103×51	4	12.62kg	13.62kg	72.7×24.2×13.6	0.84
SH-CHTQ600-4 SH-CHTA600-4	943mm	3892g±50g	1000×118×85	1	7.55kg	8.00kg	103×14.5×10	0.53
SH-CHTQ800-4 SH-CHTA800-4	1235mm	4685g±50g	1265×118×85	1	9.51kg	10.05kg	126.5×14.5×10	0.57
SH-CHTQ800-5 SH-CHTA800-5	1235mm	5030g±50g	1265×118×85	1	9.90kg	10.44kg	126.5×14.5×10	0.57
SH-CHTQ1000-4 SH-CHTA1000-4	1235mm	4685g±50g	1265×118×85	1	9.51kg	10.05kg	126.5×14.5×10	0.57
SH-CHTQ1000-5 SH-CHTA1000-5	1235mm	5030g±50g	1265×118×85	1	9.90kg	10.44kg	126.5×14.5×10	0.57

Packing Specification

Rechargeable Digital Interchangeable Torque Wrench Rechargeable Digital Interchangeable & Angle Torque Wrench

Model No.	Wrench Length	Wrench Weight	Tool Box Size L×W×H(mm)	Quantity (pcs)	Carton N.W.	Carton G.W.	Carton L×W×H(cm)	Cu.ft
SH-CHTI30-1 SH-CHIA30-1	387mm	778g±50g	460×103×51	8	15.20kg	16.20kg	48.8×24.2×25.5	1.06
SH-CHTI60-2 SH-CHIA60-2	390mm	810g±50g	460×103×51	8	15.45kg	16.45kg	48.8×24.2×25.5	1.06
SH-CHTI135-2 SH-CHIA135-2	406mm	884g±50g	578×103×51	6	13.20kg	14.20kg	60.6×24.2×19.7	1.02
SH-CHTI135-3 SH-CHIA135-3	428mm	1110g±50g	578×103×51	6	14.77kg	15.77kg	60.6×24.2×19.7	1.02
SH-CHTI200-3 SH-CHIA200-3	538mm	1270g±50g	697×103×51	4	12.05kg	13.05kg	72.7×24.2×13.6	0.84
SH-CHTI340-3 SH-CHIA340-3	638mm	1428g±50g	697×103×51	4	12.70kg	13.70kg	72.7×24.2×13.6	0.84

Rechargeable Digital Flexible Torque Wrench Rechargeable Digital Flexible & Angle Torque Wrench

Model No.	Wrench Length	Wrench Weight	Tool Box Size L×W×H(mm)	Quantity (pcs)	Carton N.W.	Carton G.W.	Carton L×W×H(cm)	Cu.ft
SH-CHTF30-1 SH-CHFA30-1	398mm	770g±50g	460×103×51	8	15.15kg	16.15kg	48.8×24.2×25.5	1.06
SH-CHTF135-2 SH-CHFA135-2	430mm	924g±50g	578×103×51	6	13.68kg	14.68kg	60.6×24.2×19.7	1.02
SH-CHTF200-3 SH-CHFA200-3	556mm	1336g±50g	697×103×51	4	12.21kg	13.21kg	72.7×24.2×13.6	0.84
SH-CHTF340-3 SH-CHFA340-3	654mm	1476g±50g	697×103×51	4	12.80kg	13.80kg	72.7×24.2×13.6	0.84

Rechargeable Digital Torque Adapter Rechargeable Digital Angle Torque Adapter

Model No.	Adapter Weight (N.W)	Adapter Size L×W×H (mm)	Tool Box Size(L) L×W×H (mm)	Tool Box Size L×W×H (mm)	Tool Box Weight N.W.	Package Weight G.W.	Carton Size Cu.ft
SH-CHTS60-1 SH-CHTSA60-1	188±5g	75×44×39mm	95×93×56mm	95×86×56mm	255g±50g	506g±50g	10pcs/carton 34.3×22.4×13cm (L×W×H) Cu.ft:0.35
SH-CHTS135-1 SH-CHTSA135-1	188±5g	75×44×39mm	95×93×56mm	95×86×56mm	255g±50g	506g±50g	
SH-CHTS200-2 SH-CHTSA200-2	192g±5g	75×44×39mm	95×93×56mm	95×86×56mm	255g±50g	506g±50g	
SH-CHTS340-2 SH-CHTSA340-2	192g±5g	75×44×39mm	95×93×56mm	95×86×56mm	255g±50g	506g±50g	

Torque Conversion Table

UNIT	mN.m	cN.m	N.m	oz.in	lb.in	lb.ft	g.cm	kg.cm	kg.m
1 mN.m	1	0.1	0.001	0.142	0.009	0.0007	10.2	0.01	0.0001
1 cN.m	10	1	0.01	1.416	0.088	0.007	102	0.102	0.001
1 N.m	1000	100	1	141.6	8.851	0.738	10197	10.2	0.102
1 oz.in	7.062	0.706	0.007	1	0.0625	0.005	72	0.072	0.0007
1 lb.in	113	11.3	0.113	16	1	0.083	1152.1	1.152	0.0115
1 lb.ft	1365	135.6	1.356	192	12	1	13826	13.83	0.138
1 g.cm	0.098	0.01	0.0001	0.014	0.0009	0.00007	1	0.001	0.00001
1 kg.cm	98.07	9.807	0.098	13.89	0.868	0.072	1000	1	0.01
1 kg.m	9807	980.7	9.807	1389	86.8	7.233	100000	100	1

Wrench Size

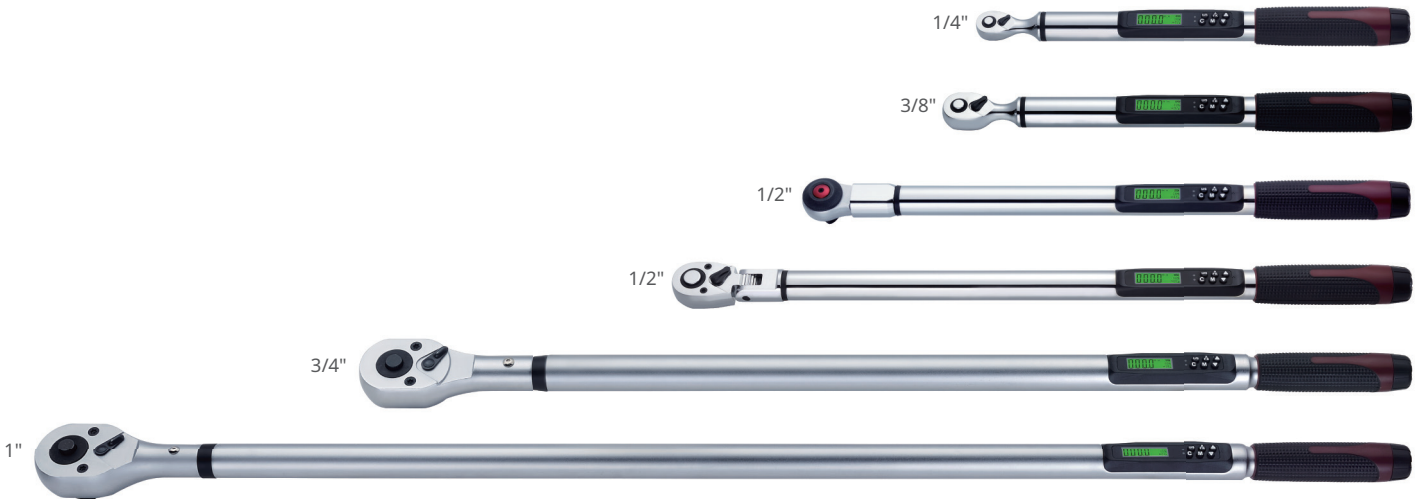



☛ No. 88, Ln. 211, Taiming Rd., Wuri Dist., Taichung City 414, Taiwan
☛ Tel: +886-4-2335-1517 ☛ Fax: +886-4-2335-1315
☛ E-mail: service@sunheng.com.tw
☛ <http://www.sunheng.com.tw>